

COMBINATION GRAPPLE
 070CHD-A RT-252-2
 COMBINE

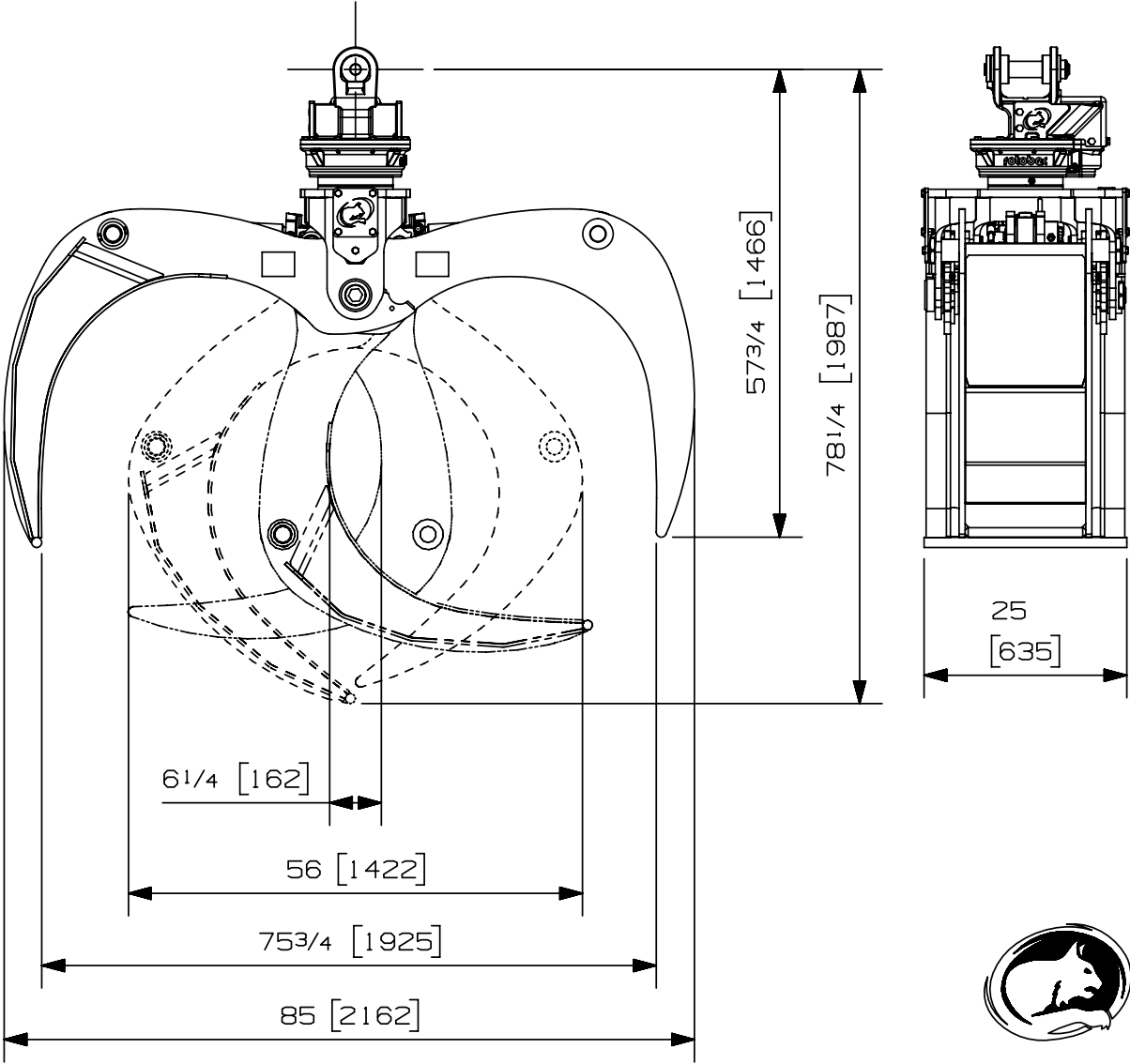

SPECIFICATION TECHNIQUE
 TECHNICAL DATA

SURFACE UTILE PTE A PTE: 0.70 m² / 7.53 ft²
 USEFUL AREA TIP TO TIP:

POIDS: 785 kg / 1730 lb
 WEIGHT:

DIA. DU CYLINDRE: 89 mm / 3 1/2 in
 CYLINDER DIAMETER:

PRESSION MAXIMUM: 344 bar / 5000 PSI
 MAXIMUM PRESSURE:

DEBIT MAXIMUM: 91 l/min / 24 GPM
 MAXIMUM FLOW:



COMBINATION GRAPPLE 070CHD-A RT-322HT-1 COMBINE

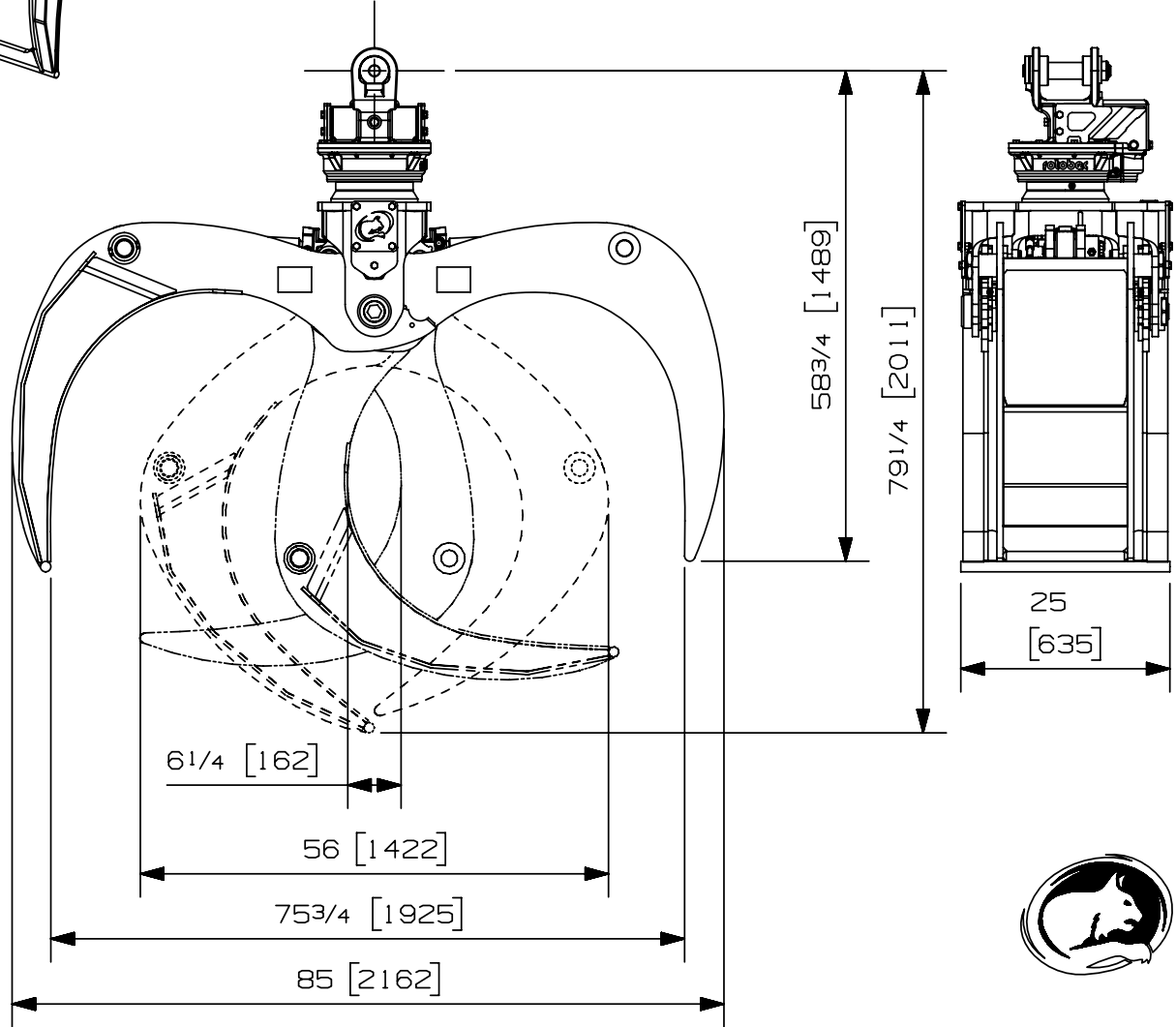
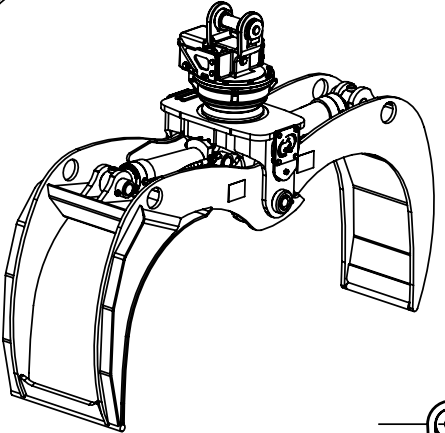

SPECIFICATION TECHNIQUE TECHNICAL DATA

SURFACE UTILE PTE A PTE:	0.70 m ² / 7.53 ft ²
USEFUL AREA TIP TO TIP:	
POIDS:	805 kg / 1770 lb
WEIGHT:	
DIA. DU CYLINDRE:	89 mm / 3 1/2 in
CYLINDER DIAMETER:	
PRESSION MAXIMUM:	344 bar / 5000 PSI
MAXIMUM PRESSURE:	
DEBIT MAXIMUM:	91 l/min / 24 GPM
MAXIMUM FLOW:	



Nous nous reservons le droit de modifier nos specifications et d'ameliorer nos produits sans autre avis ou obligation.
We reserve the right to change specifications and improve our products without notice or obligation.

COMBINATION GRAPPLE 070CHD-A RT-502STDHT-1 COMBINE

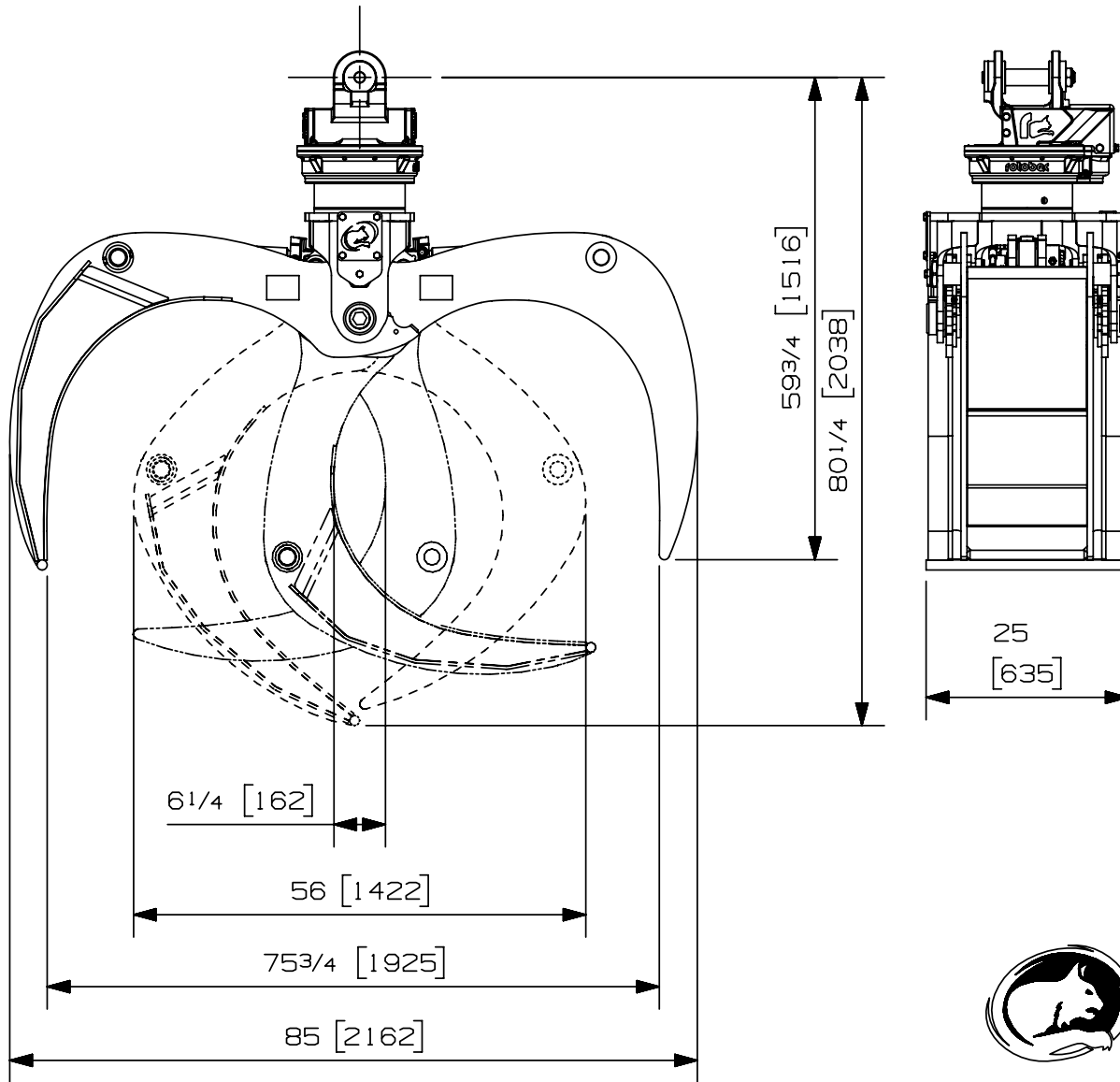

SPECIFICATION TECHNIQUE TECHNICAL DATA

SURFACE UTILE PTE A PTE: 0.70 m² / 7.53 ft²
USEFUL AREA TIP TO TIP:

POIDS: 870 kg / 1915 lb
WEIGHT:

DIA. DU CYLINDRE: 89 mm / 3 1/2 in
CYLINDER DIAMETER:

PRESSION MAXIMUM: 344 bar / 5000 PSI
MAXIMUM PRESSURE:

DEBIT MAXIMUM: 91 l/min / 24 GPM
MAXIMUM FLOW:



ROTOBEC™