

COMBINATION GRAPPLE

100CHD-A RT-502STDHT-1

COMBINE

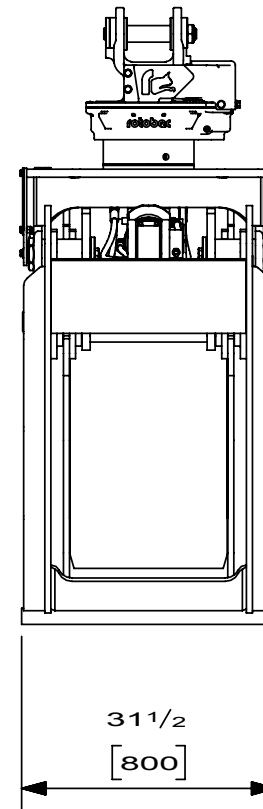
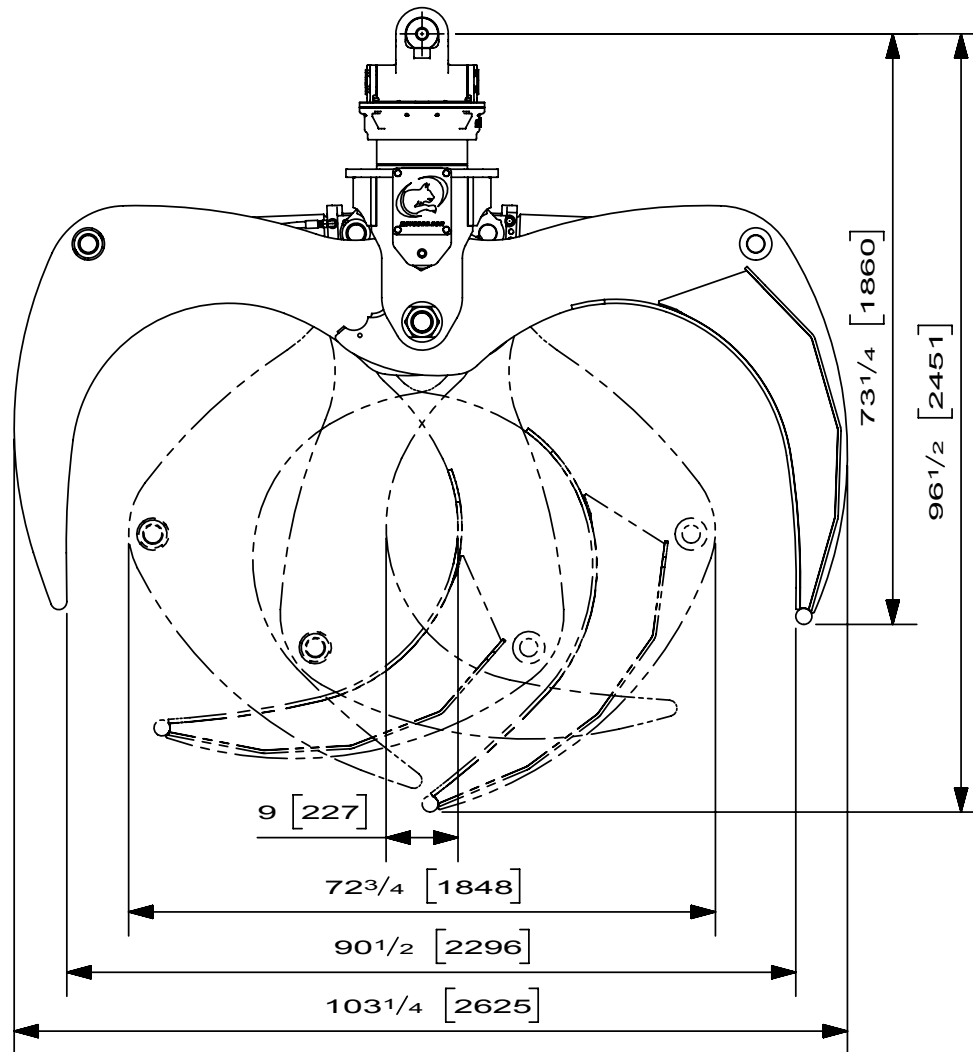

SPECIFICATION TECHNIQUE TECHNICAL DATA

SURFACE UTILE PTE A PTE: 1.00 m² / 10.26 ft²
USEFUL AREA TIP TO TIP:

POIDS: 1635 kg / 3395 lb
WEIGHT:

DIA. DU CYLINDRE: 102 mm / 4 in
CYLINDER DIAMETER:

PRESSION MAXIMUM: 344 bar / 5000 PSI
MAXIMUM PRESSURE:

DEBIT MAXIMUM: 114 l/min / 42 GPM
MAXIMUM FLOW:



ROTOBEC™

COMBINATION GRAPPLE

100CHD-A RT-1002STDHT-1

COMBINE

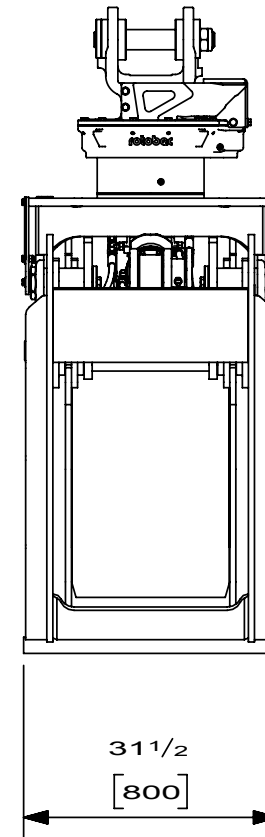
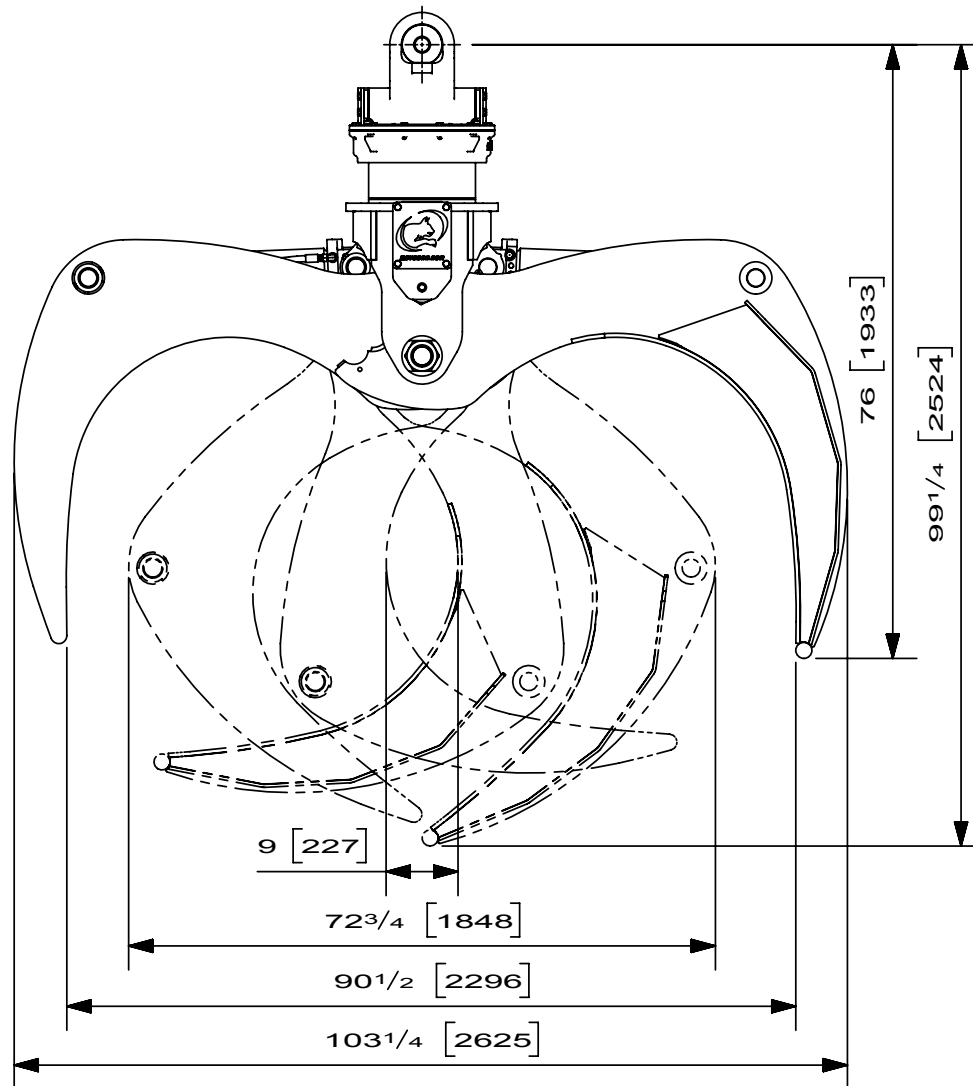

SPECIFICATION TECHNIQUE TECHNICAL DATA

SURFACE UTILE PTE A PTE: 1.00 m² / 10.26 ft²
USEFUL AREA TIP TO TIP:

POIDS: 1635 kg / 3595 lb
WEIGHT:

DIA. DU CYLINDRE: 102 mm / 4 in
CYLINDER DIAMETER:

PRESSION MAXIMUM: 344 bar / 5000 PSI
MAXIMUM PRESSURE:

DEBIT MAXIMUM: 114 l/min / 42 GPM
MAXIMUM FLOW:



ROTOBEC™