

Sorting & Demolition Grapple 2030SDR RGP-1002

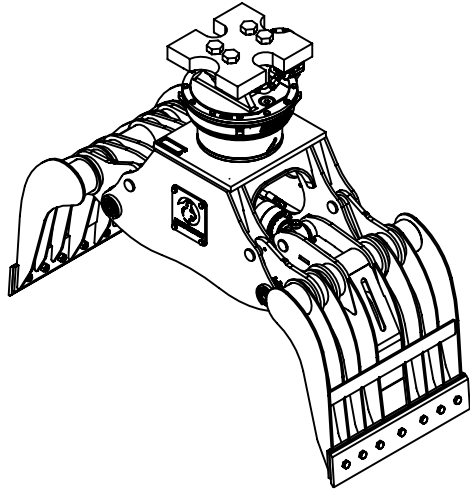

Max load:	- lb	- kg
Volume:	.67 y ³	.51 m ³
Area tip to tip:	- ft ²	- m ²
Rotator lifting capacity:	100000 lb	45359 kg
Torque at relief pressure:	21770 lb-in	2460 Nm
	913 psi	63 bars
Weight:	2140 lb	971 kg

Rotator	Maximum pressure: 4200 psi 290 bars	Recommended flow: 6 gpm 23 l/min
Rotator recommended flow will produce a maximum speed of 10 rpm		

Cylinder	Diameter	Recommended pressure	Pressure range	Flow range	Lock valves
Standard	3 1/2 " (89 mm)	4300 psi (296 bars)	3600 - 5000 psi (248-345 bars)	9 - 13 gpm (34-49 l/min.)	No

Grapple cylinder maximum flow will theoretically produce a complete grapple open/close cycle in 4 seconds.

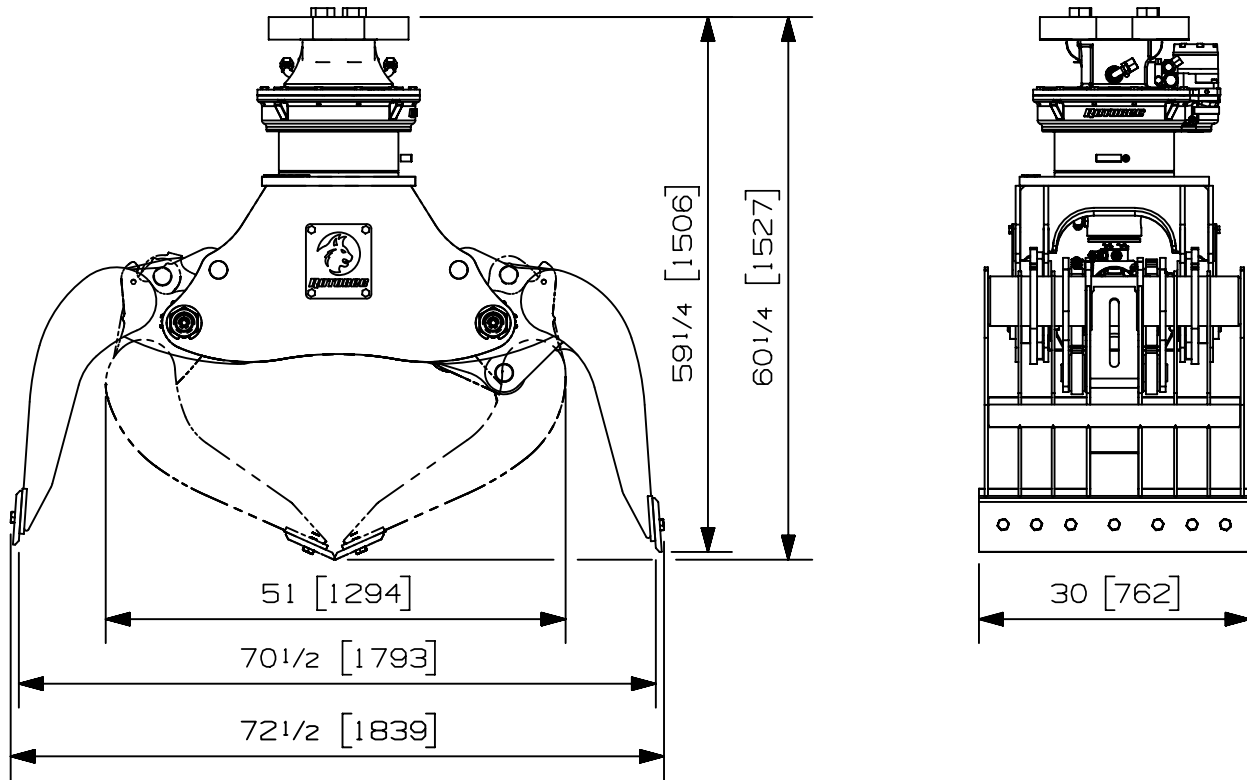

Options:

- See also RGP-1002 option for more options

-
-
-

web site: www.rotobec.com

email: rotobec@rotobec.com

Rotobec Inc.: Head office serving OEM's and Eastern Canada Ph: (418) 383-3002 Fax: (418) 383-5334
Rotobec West: Branch serving Western Canada and Western USA Ph: (250) 765-1161 Fax: (250) 765-0035
Rotobec USA: Branch serving Eastern and Central USA Ph: (603) 444-2103 Fax: (603) 444-0327

We reserve the right to change specifications and to improve our products without notice or obligation.

07008-1840
13/05/21