

# COMBINATION GRAPPLE 050CHD-A RT-252-1 COMBINE

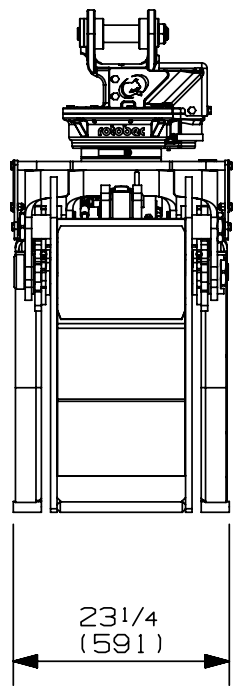

### SPECIFICATION TECHNIQUE TECHNICAL DATA

SURFACE UTILE PTE A PTE:	0.50 m <sup>2</sup> / 5.40 ft <sup>2</sup>
USEFUL AREA TIP TO TIP:	
POIDS:	621 kg / 1370 lb
WEIGHT:	
DIA. DU CYLINDRE:	89 mm / 3 1/2 in
CYLINDER DIAMETER:	
PRESSION MAXIMUM:	344 bar / 5000 PSI
MAXIMUM PRESSURE:	
DEBIT MAXIMUM:	91 l/min / 24 GPM
MAXIMUM FLOW:	

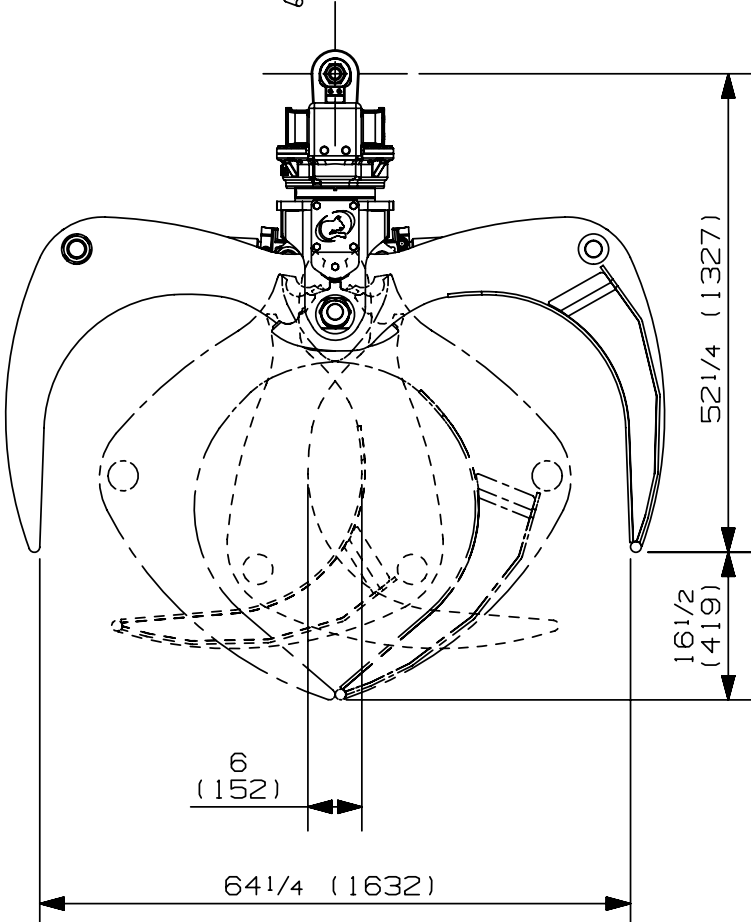
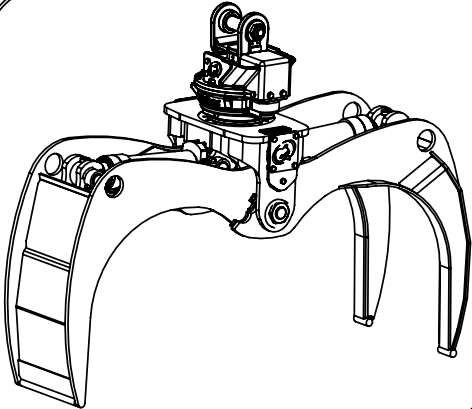

Nous nous reservons le droit de modifier nos specifications et d'ameliorer nos produits sans autre avis ou obligation.  
We reserve the right to change specifications and improve our products without notice or obligation.

# COMBINATION GRAPPLE 050CHD-A RT-322-1 COMBINE

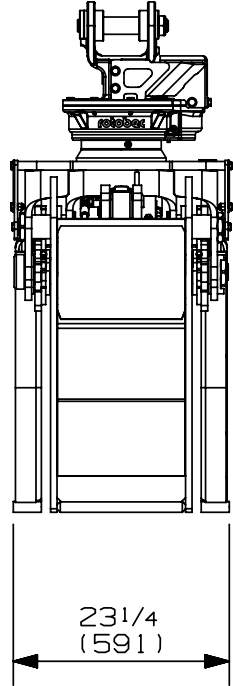
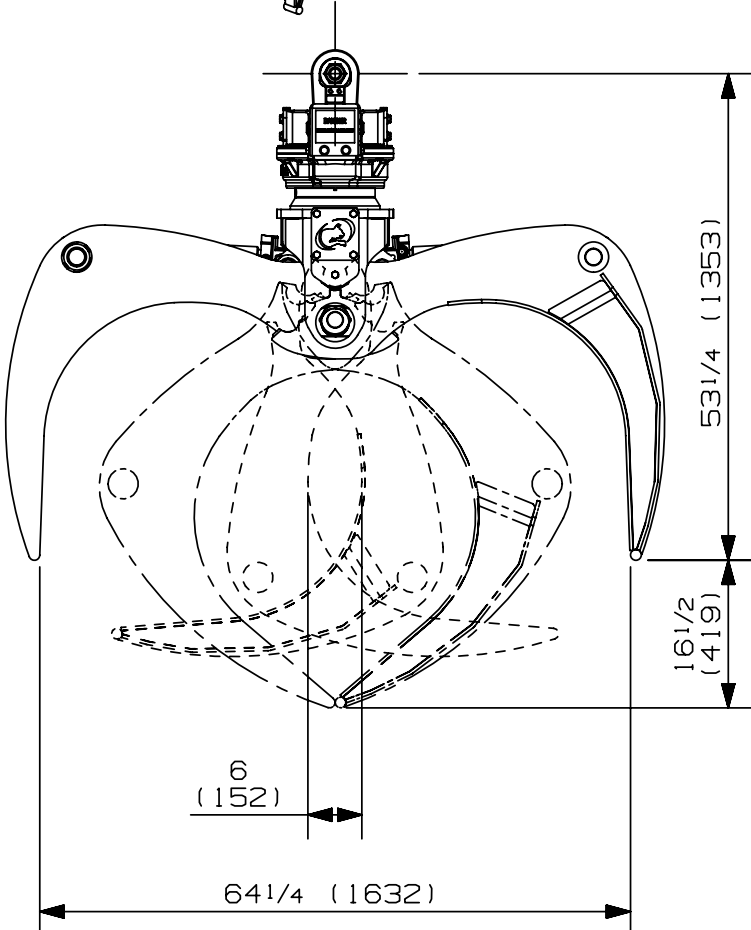
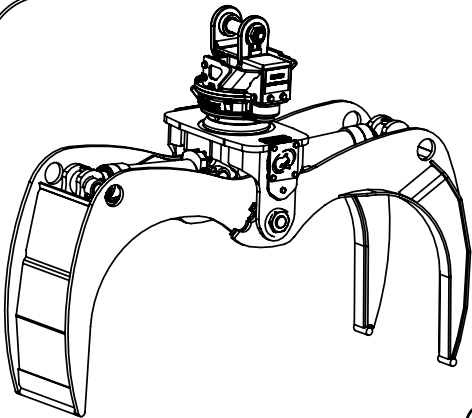

### SPECIFICATION TECHNIQUE TECHNICAL DATA

SURFACE UTILE PTE A PTE:	0.50 m <sup>2</sup> / 5.40 ft <sup>2</sup>
USEFUL AREA TIP TO TIP:	
POIDS:	640 kg / 1410 lb
WEIGHT:	
DIA. DU CYLINDRE:	89 mm / 3 1/2 in
CYLINDER DIAMETER:	
PRESSION MAXIMUM:	344 bar / 5000 PSI
MAXIMUM PRESSURE:	
DEBIT MAXIMUM:	91 l/min / 24 GPM
MAXIMUM FLOW:	



Nous nous reservons le droit de modifier nos specifications et d'ameliorer nos produits sans autre avis ou obligation.  
We reserve the right to change specifications and improve our products without notice or obligation.