

COMBINATION GRAPPLE 080CHD-A RT-502STDHT-1 COMBINE

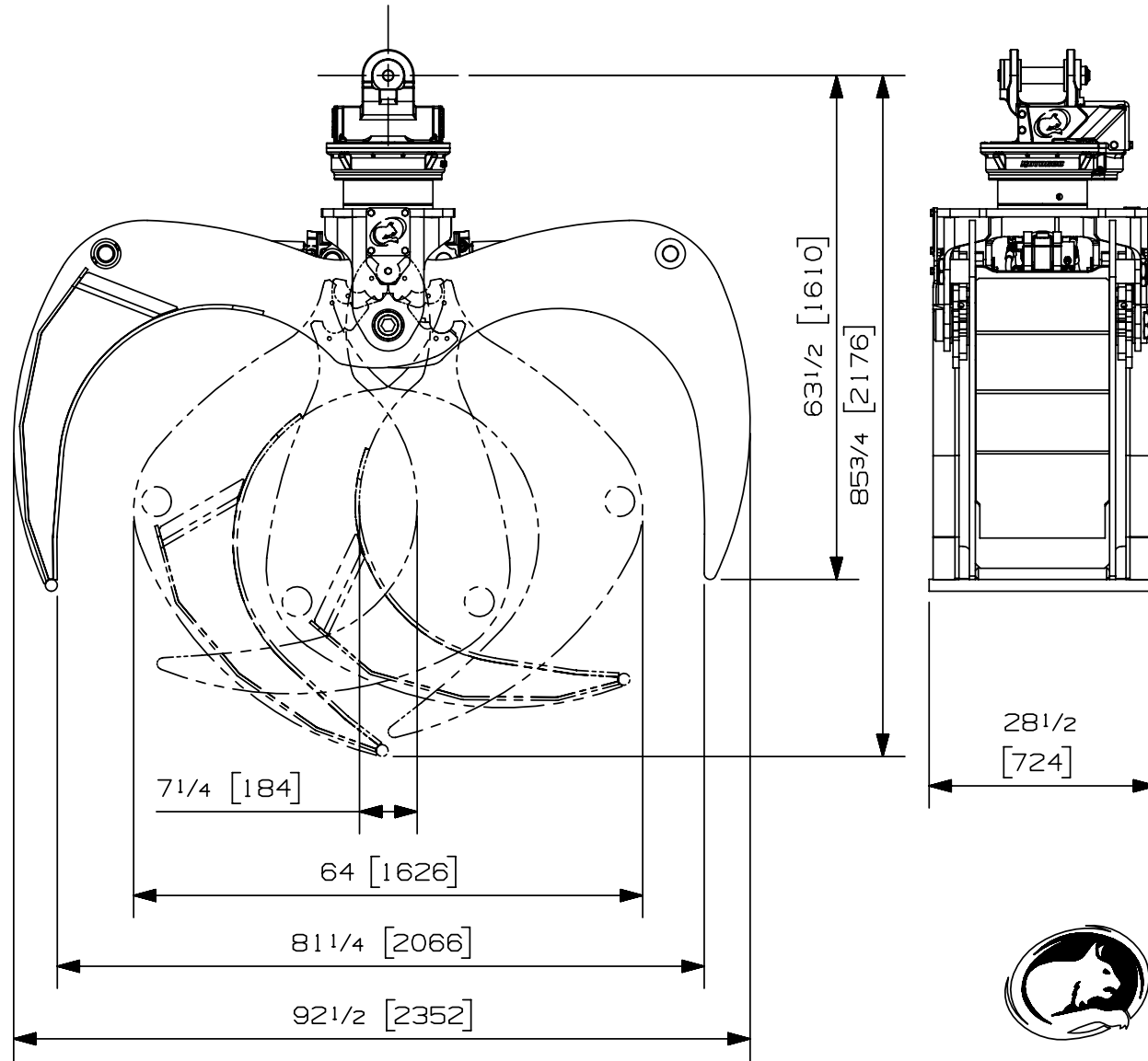

SPECIFICATION TECHNIQUE TECHNICAL DATA

SURFACE UTILE PTE A PTE: 0.80 m² / 8.61 ft²
USEFUL AREA TIP TO TIP:

POIDS: 1140 kg / 2510 lb
WEIGHT:

DIA. DU CYLINDRE: 89 mm / 3 $\frac{1}{2}$ in
CYLINDER DIAMETER:

PRESSION MAXIMUM: 344 bar / 5000 PSI
MAXIMUM PRESSURE:

DEBIT MAXIMUM: 117 l/min / 31 GPM
MAXIMUM FLOW:



ROTOBEC™