

COMBINATION GRAPPLE 150CHD-B RT-1002STDHT - 1 COMBINE

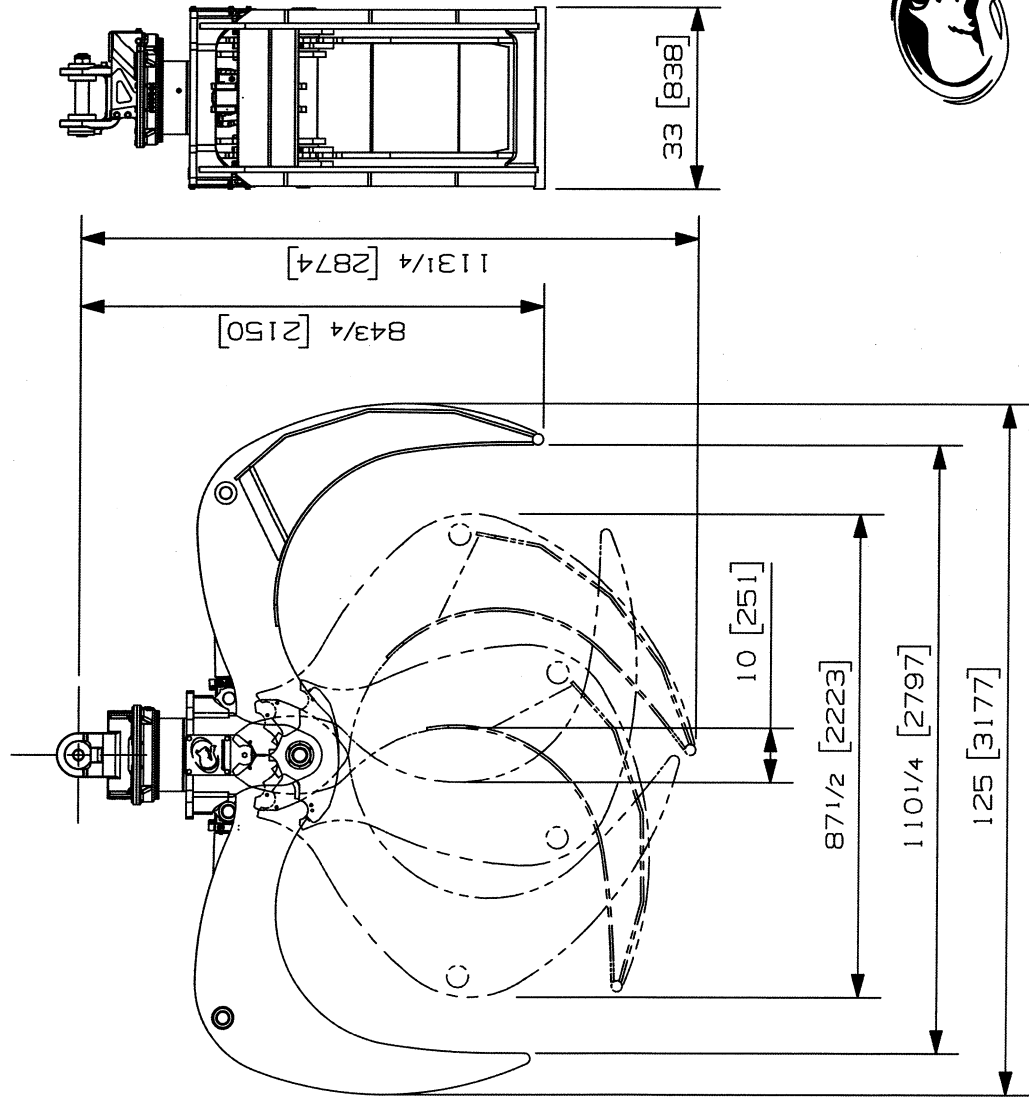

SPECIFICATION TECHNIQUE TECHNICAL DATA

SURFACE UTILE PTE. A PTE: 1.50 m² / 16.14 ft²
 USEFUL AREA TIP TO TIP:
 POIDS: 2268 kg / 4995 lb
 WEIGHT:
 DIA. DU CYLINDRE: 102 mm / 4 in
 CYLINDER DIAMETER:
 PRESSION MAXIMUM: 344 bar / 5000 PSI
 MAXIMUM PRESSURE:
 DEBIT MAXIMUM: 159 l/min / 42 GPM
 MAXIMUM FLOW:



Nous nous reservons le droit de modifier nos specifications et d'ameliorer nos produits sans autre avis ou obligation.
 We reserve the right to change specifications and improve our products without notice or obligation.

07003-3273/00
 13/02/13
 DESSIN (DWG)