

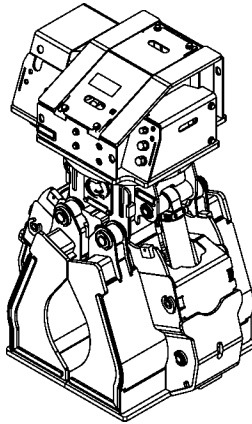

# Power Attachment

## RPA3045C with rotator RGP-902LT



<b>Opening</b>	69 3/4 in. (1772 mm)
<b>Closing</b>	12 1/4 in. (311 mm)
<b>Volume</b>	0.4 cubic yards    .31 cubic meters
<b>Area tip to tip</b>	N/A
<b>Rotator lifting capacity</b>	90000 lb (40823 kg)
<b>Torque at relief pressure</b>	51150 in.lb (5780 Nm)    @ 1800 psi (124 bars)
<b>Steel* thickness</b>	
<b>Weight</b>	3130 lb (1420 kg)

\*High tensile strength steel: 165,000 psi (1138 MPa)

<b>Rotator</b>	<b>Maximum pressure:</b> 5000 psi (345 bars)	<b>Recommended flow:</b> 12 gpm (45 l/min.)
----------------	--	---

Rotator recommended flow will produce a speed of 15 rpm.

Cylinder	Diameter	Recommended pressure	Pressure range	Flow range	Lock valves
Standard	3 1/2" (89 mm)	4000 psi (276 bars)	3000 - 5000 psi (207 - 345 bars)	14 - 20 gpm (53 - 76 l/min.)	no

Grapple cylinder maximum flow will theoretically produce a complete grapple open/close cycle in 4 seconds.

Reference	Dimension
A	12 1/4 in. (311 mm)
B	69 3/4 in. (1772 mm)
C	83 in. (2108 mm)
D	50 1/2 in. (1283 mm)
E	67 1/4 in. (1708 mm)
F	35 in. (889 mm)
G	

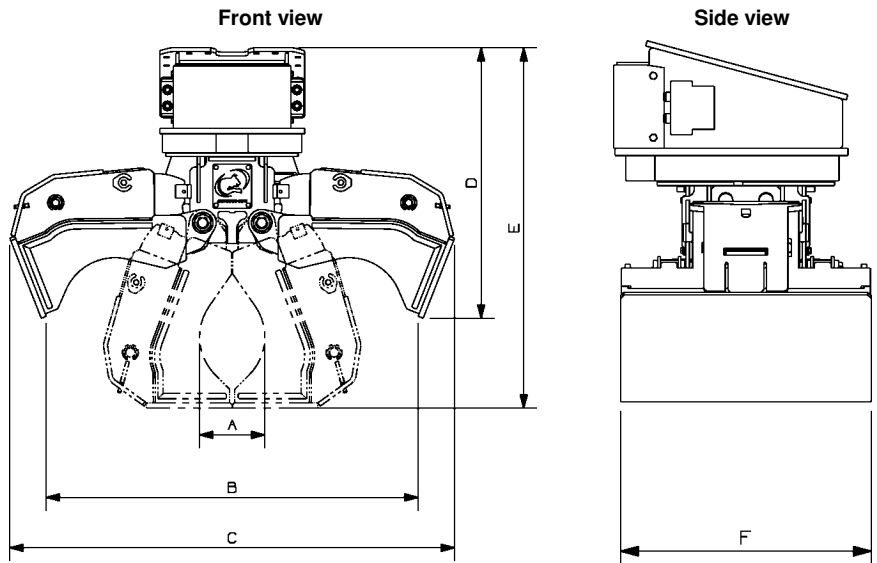

OPTIONS: Custom lugging on rotator. Float on swing motor. Positioning cylinder kit, including bracket. 2 function valve-in-head kit. Installation kit.

web site: [www.rotobec.com](http://www.rotobec.com)

e-mail: [rotobec@rotobec.com](mailto:rotobec@rotobec.com)

Rotobec Inc.: Head office serving OEM's and Eastern Canada  
 Rotobec West: Branch serving Western Canada and Western USA  
 Rotobec USA: Branch serving Eastern and Central USA

Ph: (418) 383-3002    Fax: (418) 383-5334  
 Ph: (250) 765-1161    Fax: (250) 765-0035  
 Ph: (603) 444-2103    Fax: (603) 444-0327